

# MAGIS

Brut by Konstantin Grcic



# Konstantin Grcic



## Profile:

Konstantin Grcic (\*1965) was trained as a cabinet maker at The John Makepeace School for Craftsmen in Wood before studying Design at the Royal College of Art in London. Today Konstantin Grcic Design is based in Berlin and active in several fields ranging from industrial design projects, exhibition design and collaborations in architecture and fashion.

Among his producers, besides Magis, are Artek, Authentics, Cassina, ClassiCon, Flos, Flötotto, Kettal, Laufen, Mattiazzi, Muji, Mutina, Nespresso, Plank, Serafino Zani and Vitra. From the fashion and lifestyle sector, Audi, Hugo Boss, Issey Miyake, Louis Vuitton, Prada,

Rado and smart/Daimler are some of his clients. Many of his products have been awarded international design prizes. He received the Compasso d'Oro in 2001 for the Mayday lamp (Flos), 2011 for the Myto chair (Plank) and 2016 for the OK lamp (Flos). For Tom and Jerry from Magis' series The Wild Bunch he received the German Design Award in Gold in 2011.

Grcic defines function in human terms, combining formal strictness with considerable mental acuity and humour. His work is characterised by a careful research into the history of art, design and architecture and his passion for technology and materials.



# Design and

The starting point of this project was a specific manufacturing method: cast iron. It is one of the oldest ways of using ferrous metals. The manufacturing process has a physicality and rawness which is almost archaic. Iron foundries are heavy industries. Even though cast iron is widely known for its ornate and decorative applications, such as in Victorian-era garden furniture, the material has two distinctive characteristics: it is heavy, and it is strong. Cast iron performs well under compression, which is why it is used as a structural material for building bridges and, closer to the scale of furniture, bases for heavy machinery.

It is this use of cast iron which has inspired this collection designed by Konstantin Grcic. The project makes reference to cast iron's typical industrial uses and applies its material grammar to the realm of contemporary furniture.

The name stands for raw and untreated. A solid piece of iron, heavy and uncompromising. But Brut also calls to mind the sweetness of sparkling wine, which speaks of refinement and sophistication, which is also inherent to our project. With its original, fresh, feisty style, it encapsulates a sense of function and aesthetics that speaks volumes about the era we are living in, and it is instantly likeable, leaving people with a clear memory both of it and of the place where they saw it.

The Brut collection consists of a rectangular table, a height-adjustable trestle table, a round table, a small bistro table, two kinds of benches, as well as an armchair and a two or three-seater sofa.



# Engineering



A surprising combination of almost contradictory mate-

rials and techniques. Hence the name “Brut”!



# Product

# Information

## ARMCHAIR

Frame in cast iron painted in polyester powder. Cushion in expanded polyurethane, fireproof (class 1IM), with removable cover in fabric.

## SOFA

Frame in cast iron painted in polyester powder. Cushion in expanded polyurethane, fireproof (class 1IM), with removable cover in fabric.

## BENCH

Frame in cast iron painted in polyester powder. Seat in oak natural.

## TABLES

Table 260x90 / 200x90

Frame in cast iron painted in polyester powder. Joining element in oak natural. Various tops available.

Table Ø 60

Base in cast iron cataphoretically treated and painted in polyester powder with integrated wheel. Column in steel cataphoretically treated and painted in polyester powder. Various tops available. Suitable for outdoor use.

Table Ø 130

Frame in cast iron painted in polyester powder. Tops in Carrara and Marquinia marble.

Table 280x95 / 260x90 / 200x90

Pair of trestles adjustable in height in cast iron painted in polyester powder. Can be ordered separately. Top in veneered oak (280x95 / 260x90 / 200x90) or in steel plate electrogalvanized (280x95) and painted in polyester powder. Can be ordered separately.



## ARMCHAIR



Frame in cast iron /  
 Grey anthracite  
 Grey anthracite

Upholstery /  
 Fabric cat 1  
 Fabric cat 2

## TWO-SEATER SOFA



Frame in cast iron /  
 Grey anthracite  
 Grey anthracite

Upholstery /  
 Fabric cat 1  
 Fabric cat 2

## THREE-SEATER SOFA



Frame in cast iron /  
 Grey anthracite  
 Grey anthracite

Upholstery /  
 Fabric cat 1  
 Fabric cat 2

## Materials /

Frame in cast iron /

Fabric cat 1 /

Fabric cat 2 /



Grey  
 Anthracite  
 5142

Kvadrat Divina MD  
 Kvadrat Divina Melange  
 Kvadrat Hero  
 Kvadrat Vidar

Torri Lana Rico  
 Glamour Azimut

## Armchair

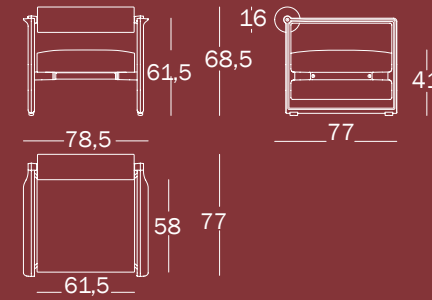

## Two-seater sofa

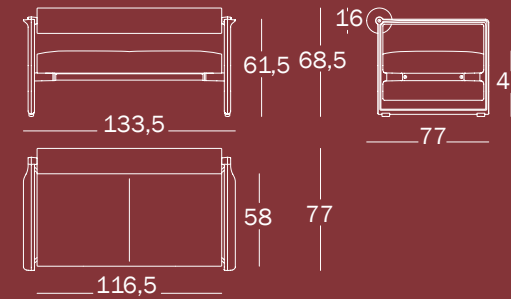

## Three-seater sofa

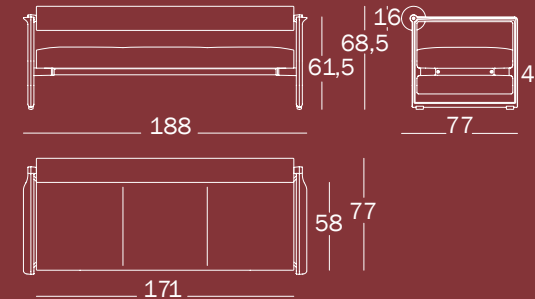

## PRODUCT CARE

Daily care and immediate stain removal will ensure that your wool upholstery will keep looking good for many years to come. It is normally sufficient to regularly vacuum and air upholstered product. Never use undiluted cleaning agents, bleaching agents, ammonia or soap intended for hard surfaces. As a general rule, many types of stain can be removed using warm water. For greasy stains, use a dry stain remover. For more insoluble stains (chewing gum, candle wax, etc.), use a plastic bag filled with ice to rub the stain until the substance has become friable. Use a clean flat blunt blade to delicately remove the substance. Be careful when using solvents, because these could dissolve the upholstery material beneath.

## WARNING

Do not use different cleaning products from the ones mentioned above. Do not use the product in an improper way. Do not place hot objects on it, sit down on the back, stand on the seat or use the product as a ladder. Once disused, please make sure this product is disposed in an environment-friendly way. For the fabric version: treat stains immediately, the longer they remain in the fabric, the harder it is to remove them. Before choosing a cleaning method, always try it out on a concealed part of the product. Magis is not liable for any damage to property or persons caused by an improper use of this product.



Fabric cat 1 /

Kvadrat Divina MD

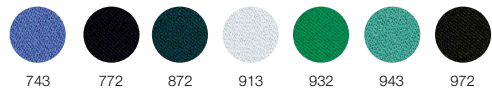
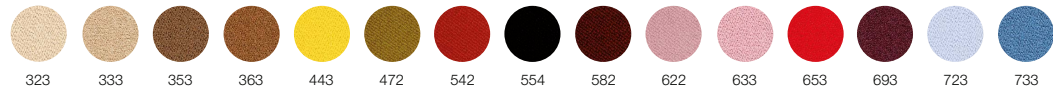
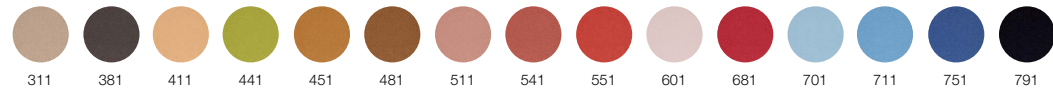
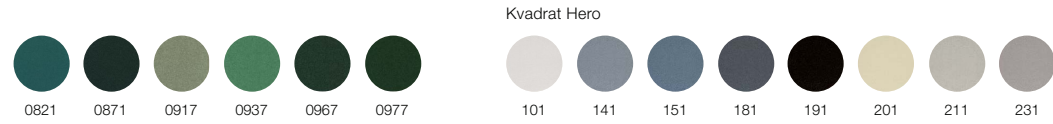
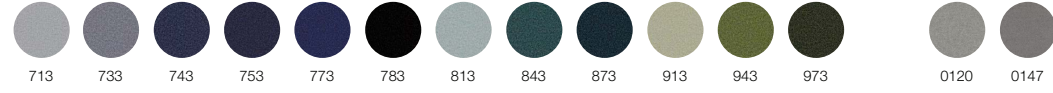

Kvadrat Divina Melange

Fabric cat 2 /

Torri Lana Rico



Glamour Azimut

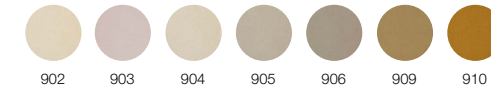
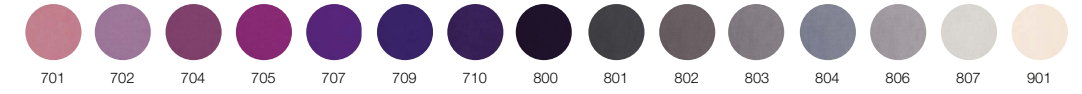



BRUT

## BENCH



Frame in cast iron /  
Colours

Seat /  
Natural oak

Materials /

Frame in cast iron /



Green  
5126



Grey  
Anthracite  
5142



Red  
5143

Seat in oak /



Natural  
oak

220x35

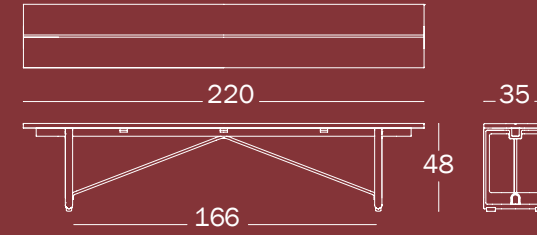

220x63

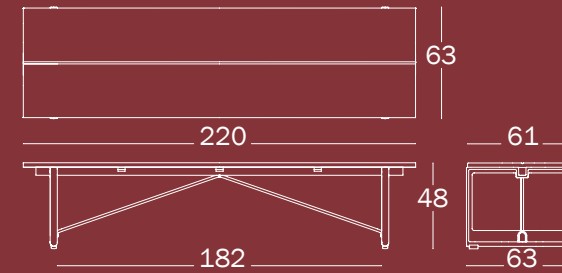

### PRODUCT CARE

We recommend using a soft rag, either dry or wet. When needed, use ph-balanced soap diluted in water. Do not use abrasive sponges as they may leave scratches. Avoid using acidic products, solvents and products containing ammonia. We recommend using ph-balanced liquid soap especially formulated for wood, diluted in water. Periodic and correct maintenance allows the product to keep its original aspect and lengthens the duration of its performance.

### WARNING

Do not use different cleaning products from the ones mentioned above. Do not use the product in an improper way. Do not place hot objects on it, stand on it or use the product as a ladder. Once disused, please make sure that this item is disposed of in an environmentally-friendly way.



BRUT



BRUT



BRUT



## TABLES

Table 260x90 / 200x90



Frame in cast iron /  
Green / Grey / Red  
Green / Grey / Red  
Green / Grey / Red

Top /  
Tempered clear glass  
Tempered smoked glass  
Veneered oak

Table Ø60



Frame in cast iron /  
Green / Grey / Red  
Green / Grey / Red  
Green / Grey / Red  
Green / Grey / Red

Top /  
HPL white 8500  
HPL black 8510  
Carrara marble white  
Marquinia marble black

Table Ø130



Frame in cast iron /  
Green / Grey / Red  
Green / Grey / Red

Top /  
Carrara marble white  
Marquinia marble black

Table 280x95 / 260x90 / 200x90



Frame in cast iron /  
Green / Grey / Red / White  
Green / Grey / Red / White

Top /  
Veneered oak  
Steel sheet black (280x95 only)

### Materials /

#### Frame in cast iron /

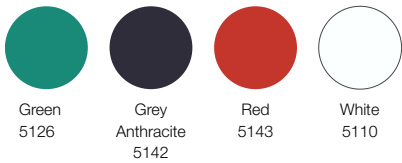

#### Top /

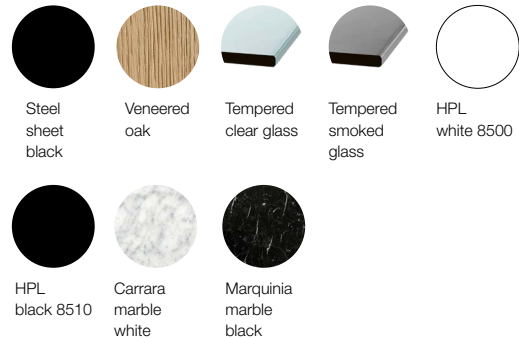

260X90

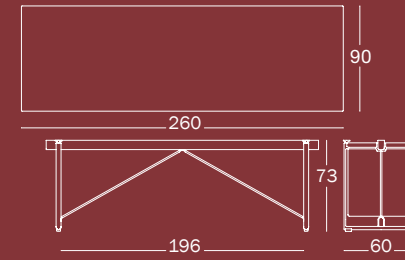

200x90

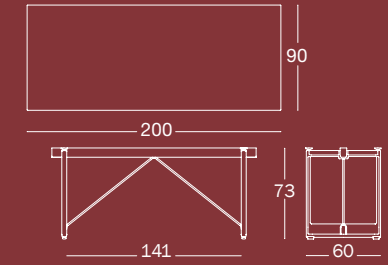

Ø60

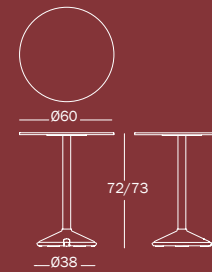

Ø130

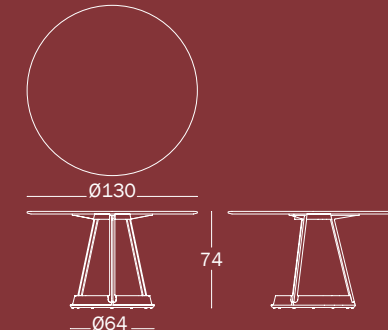

280X95



260x90 / 200x90

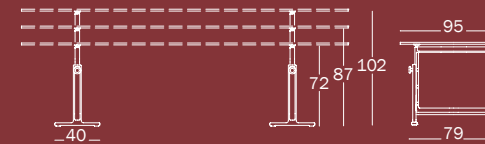

### PRODUCT CARE

We recommend using a soft rag, either dry or wet. When needed, use ph-balanced soap diluted in water. Do not use abrasive sponges as they may leave scratches. Avoid using acidic products, solvents and products containing ammonia. For tops in wood, we recommend using ph-balanced liquid soap especially formulated for wood, diluted in water. For tops in marble we recommend using water and Marseilles soap for cleaning. To remove greasy substances and various stains it is possible to use ammoniacs, denatured alcohol, bicarbonate and hydrogen peroxide. To remove scratches caused by a standard use of the top, rub the surface with a damp leather cloth. Any marks, signs or irregularities that may be visible on the stone tops are peculiarities of the materials and should not be considered as faults. Periodic and correct maintenance allows the product to keep its original aspect and lengthens the duration of its performance.

### WARNING

Do not use different cleaning products from the ones mentioned above. Do not use the product in an improper way. Do not place hot objects on it, stand on it or use the product as a ladder. Once disused, please make sure that this item is disposed of in an environmentally-friendly way.



